



Autogas's Perfect Storm?

Eric Johnson

Atlantic Consulting

ejohnson@ecosite.co.uk

A distinctive point in LPG's history

- Direct-injection on the rise
- Well-to-tank footprint declining
- Supply booming
- Dieselpgate prompting a regulatory re-think

The rise of DI (spark-ignited)

- First came the rise of diesel in Europe
 - OEMs
 - Refiners
 - Governments
- Now comes the rise of DI for gasoline (and LPG)

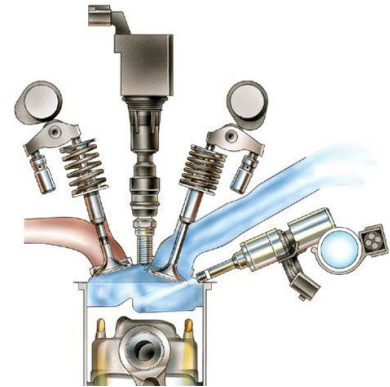
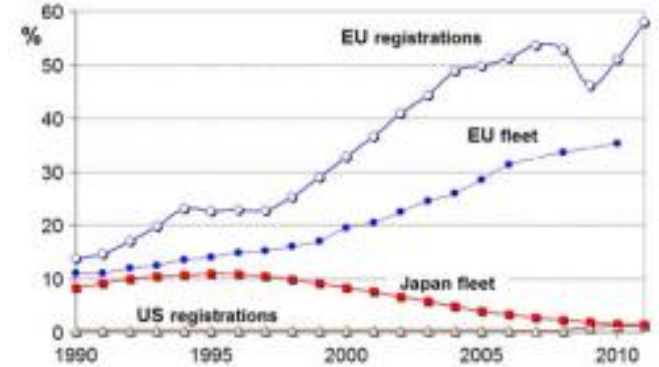

What's so great about DI?

- Higher compression ratio
- Closer control of fuel
 - Non valve-dependent
 - Stratified charge
- More cylinder-cooling from the fuel

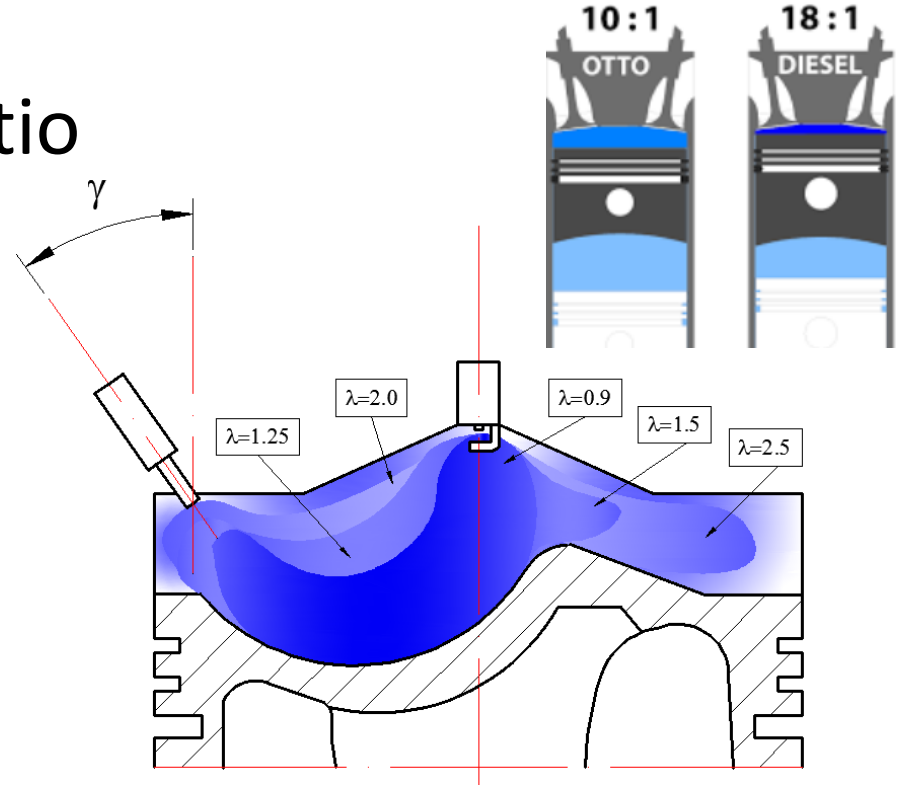

What's so great about LPG DI?

- Even higher compression ratio, thanks to higher octane
- So, higher efficiency and less CO₂
- Little-to-no particle emissions

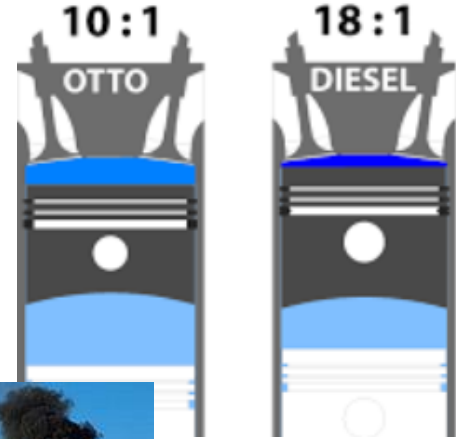

Well-to-tank footprints reconsidered

- EU Fuel Quality Directive footprints (well-to-wheel)
 - Diesel: 95.1 g CO₂e/MJ
 - Petrol: 93.3
 - LNG: 74.5
 - LPG: 73.6
 - CNG: 69.3
- Co-production and refining are (finally) being reviewed

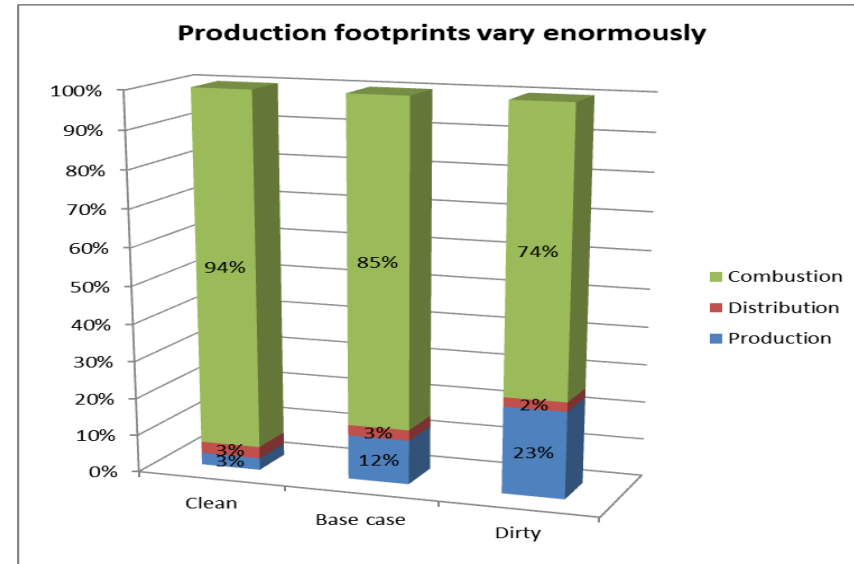

The rise of pedigreed fuels?



Biofuels do this already!

Dieseldate rewriting the rulebook



Two issues at stake: One is **cheating**.



The other is **NOT** about cheating.



Although there are concerns...

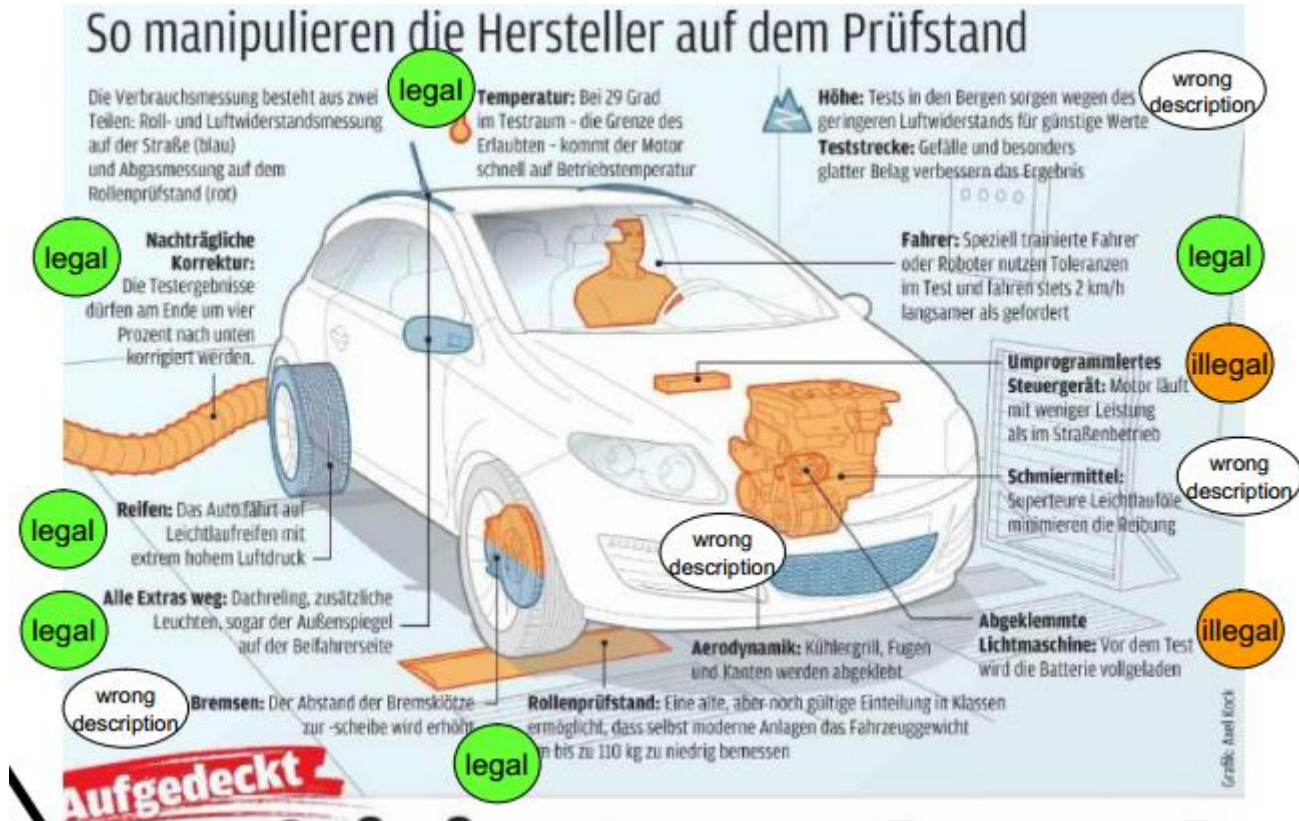

Dynamometer testing is valuable!



KBA data tells a story

A comparative Environmental Impact Assessment of car-and-van fuels

Petrol, diesel, LPG & CNG

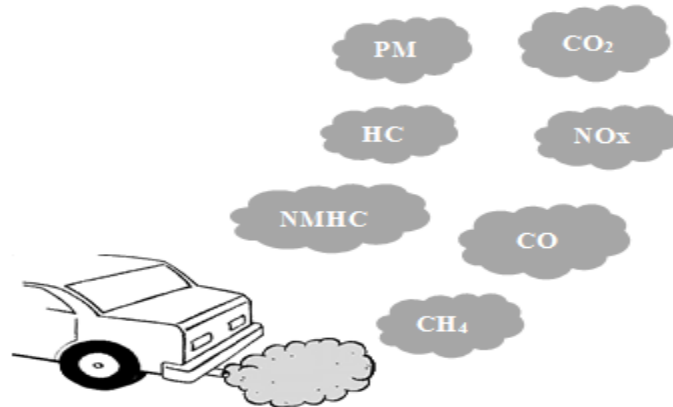

For Autogas - opportunity knocks!

- Direct-injection on the rise
- Well-to-tank footprint declining
- Supply is booming
- Dieselpgate prompting a regulatory re-think

Eric Johnson

Atlantic Consulting

ejohnson@ecosite.co.uk